

# PIPE TAP DIMENSIONS – STRAIGHT AND TAPER Table 311

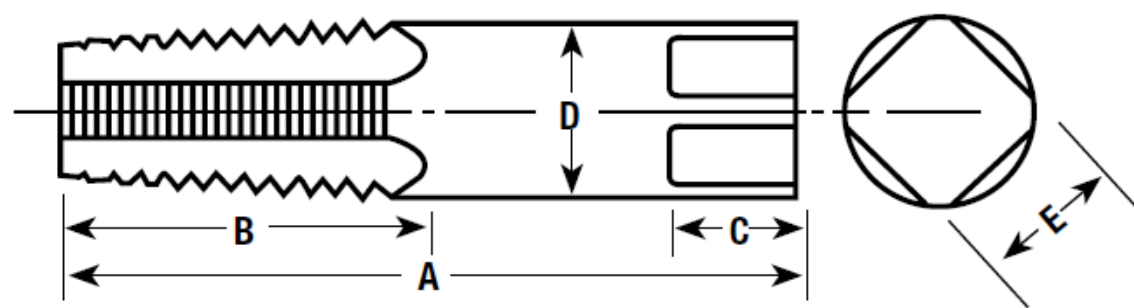

Nominal Size Inches	Standard Projection	Minimum Projection	A Overall Length	B Thread Length	C Square Length	D Shank Diameter	E Size of Square
1/16	.312	Flush ("0" Proj.)	2-1/8	11/16	3/8	.3125	.234
1/8*	.312	Flush ("0" Proj.)	2-1/8	3/4	3/8	.3125	.234
1/8	.312	Flush ("0" Proj.)	2-1/8	3/4	3/8	.4375	.328
1/4	.459	.218	2-7/16	1-1/16	7/16	.5625	.421
3/8	.454	.150	2-9/16	1-1/16	1/2	.7000	.531
1/2	.579	.260	3-1/8	1-3/8	5/8	.6875	.515
3/4	.565	.245	3-1/4	1-3/8	11/16	.9063	.679
1	.678	.275	3-3/4	1-3/4	13/16	1.1250	.843
1-1/4	.686	.285	4	1-3/4	15/16	1.3125	.984
1-1/2	.699	.300	4-1/4	1-3/4	1	1.5000	1.125
2	.667	.267	4-1/2	1-3/4	1-1/8	1.8750	1.406
2-1/2	.925	.525	5-1/2	2-9/16	1-1/4	2.2500	1.687
3	.925	.525	6	2-5/8	1-3/8	2.6250	1.968
3-1/2	.938	.525	6-1/2	2-11/16	1-1/2	2.8125	2.108
4	.950	.525	6-3/4	2-3/4	1-5/8	3.0000	2.250

## TAPER PIPE REAMERS High Speed Steel

Nominal Size - Inches High Speed Steel	Diameter Large End	Diameter Small End	Dimensions - Inches		Size of Square	Overall Length
			Length of Flutes	Diameter of Shank		
1/8	.362	.316	3/4	.4375	.328	2-1/8
1/4	.472	.406	1-1/16	.5625	.421	2-7/16
3/8	.606	.540	1-1/16	.7000	.531	2-9/16
1/2	.751	.665	1-3/8	.6875	.515	3-1/8
3/4	.962	.876	1-3/8	.9063	.679	3-1/4
1	1.212	1.103	1-3/4	1.1250	.843	3-3/4
1-1/4	1.553	1.444	1-3/4	1.3125	.984	4
1-1/2	1.793	1.684	1-3/4	1.5000	1.125	4-1/4
2	2.268	2.159	1-3/4	1.8750	1.406	4-1/2